

## INSTRUCTION MANUAL

### Wardrobe lift 717

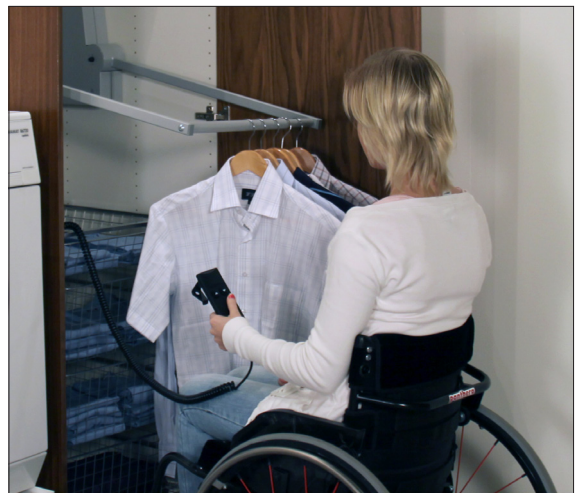



**For more information, see:  
[www.granberg.se](http://www.granberg.se)**

# Content

---

Section:	Headline:	Page:
1.	Introduction.....	4
2.	Declaration of Conformity.....	4
3.	Intended use - Technical data.....	4
	<b>Installation instructions:</b>	
4.1	Mechanical construction.....	5
4.2	Delivery modules .....	5
4.3	Location of electric connections .....	5
4.4	Installation of the lifting mechanism .....	6
4.5	Location of push button unit .....	9
4.6	Operational test.....	9
	<b>Operator's information:</b>	
5.1	Safe use.....	10
5.2	Load distribution and side forces .....	11
5.3	Actions after use.....	11
5.4	Control device options .....	11
5.5	Cleaning.....	12
5.6	Maintenance .....	12
6.	Instructions for Recycling.....	12
7.	Decals.....	13
8.	Warranty .....	13
9.	Service & maintenance records.....	13
10.	Faultfinding.....	14
11.	Spare parts list.....	14
12.	Electric circuit diagram.....	15
13.	CE-declaration of Conformity .....	15

## 1. Introduction

We have the pleasure to deliver a Granberg Interior Wardrobe lift 717, an electrically operated lifting and lowering system for installation in new or existing wardrobes.

The Wardrobe lift has got a clothes-rail, where clothes can be hung. With the push button box the motorized clothes-rail is lowered to a convenient height for handling the clothes.  
The lift has adjustable width and there are two models.

### **Only authorized persons may use the Wardrobe lift!**

Authorization means obligation to read and follow the instructions.

It is very important that you read and understands the instructions before you use the device.  
If you have any questions - contact your supplier.

This Instruction manual shall be available for all concerned persons, be kept in a protected place and shall follow the product, if it is moved to another installation site or another house or apartment owner.

### **Correct use, operation, inspections and maintenance are decisive for efficient and safe work.**

## 2. Declaration of Conformity with EU-directives

This product is CE-marked and is granted to conform to the basic safety and operation requirements, in accordance with de actual Machinery, EMC- and Low voltage Directives. A separate "CE-Declaration of Conformity" is available in section 13.

## 3. Intended use - Technical data

The Wardrobe lift 717 is intended to vertically lift and lower clothes on the clothes-rail to and from the wardrobe. The operation shall be indoors under normal housing conditions regarding temperature, humidity and lighting.

The Wardrobe lift must not be used in humid rooms.

### **Technical data, Wardrobe lift 717:**

<b>Model:</b>	<b>717-06063</b>	<b>717-08063</b>
Cabinet width, inside	560 - 668 mm	760 - 1168 mm
Cabinet height, inside	Adjusted for the length of the clothes	Adjusted for the length of the clothes
Cabinet depth, inside	Adjusted for the width of the clothes	Adjusted for the width of the clothes
Vertical stroke, max	820 mm	820 mm
Horizontal stroke, max	820 mm	820 mm
Machine height, vertical arm	840 mm	840 mm
Machine height, lowered arm	1000 mm	1000 mm
Time for a lift or lowering stroke, approx	14 sec	14 sec
Mains supply*	120 V 6 A / 230 V 2,5 A	120 V 6 A / 230 V 2,5 A
El. protection class	IP 20	IP 20
Power consumption	575 W	575 W
Max no. of full work cycles per hour	6	6
Control voltage	24 V DC	24 V DC
Weight	15 kg	15 kg
Max load on the clothes-rail	20 kg	20 kg
The noise pressure is less than	70 db(A)	70 db(A)

\* The voltage depends on which model that is delivered.

## 4.1 Mechanical construction

The Wardrobe lift 717 comprises two lift mechanisms, to be placed on the left and right side in the wardrobe. The rail tube connects the mechanisms together. See picture 1.

The curved lifting and lowering motion is achieved by an electrically powered screw jack with a control unit, containing a contactor and the control voltage transformer for 24 V DC control voltage.

Picture 1



## 4.2 Delivery modules

The Wardrobe lift is delivered in a box. The parts acc. picture 2 shall be installed acc. to the installation instruction. See section 4.4.

The packaging material shall be handed over to an organized material re-cycling organisation.

- A - Lift mechanism, left
- B - Lift mechanism, right
- C - Control unit
- D - Handheld control unit with spiral cable
- E - Rail tube
- F - Hanger for handheld control
- G - 12 off screw 4x16 mm

Picture 2

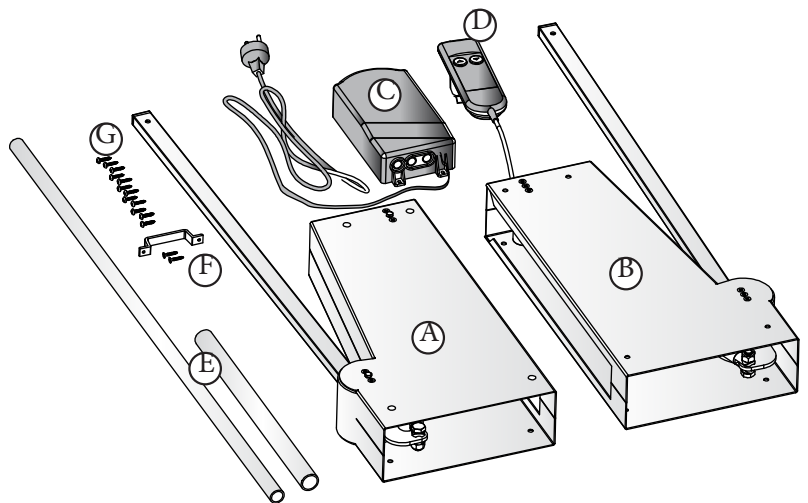

## 4.3 Location of the electric connection

**The Wardrobe lift must be connected to a separate mains switch, which is placed outside the wardrobe.**

A projecting socket 230 V, 50 Hz / 120 V 60 Hz shall be installed in the wardrobe acc. picture 3, 5 cm below the lifting mechanism, on the cabinet side.

**Be careful with the location and fastening of the cables, so that they cannot be damaged**

\* Power consumption 720 W (120 V) or 575 W (230 V)

Picture 3

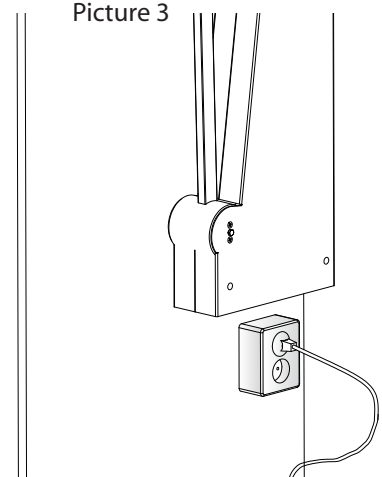

**Only an authorized electrician may carry out the installation!**

## 4.4 Installation of the lift mechanism and guide arm

### To consider before installation:

The dimensions of the wardrobe must be suitable for the size of the Wardrobe lift as well as for the space required for the clothes. A standard wardrobe with inside height 1918 mm and depth minimum 565 mm is suitable. The location of the lift is adapted for the wardrobe size, the clothes and the desired height when lowered.

Do not place the Wardrobe lift so that the clothes and the clothes-rail goes too low, as this increases the risk for damaging persons as well as the clothes. Also do not place the Wardrobe lift too high, as there will be a trapping risk between the Wardrobe lift and the wardrobe ceiling.

Plan the location of the Wardrobe lift in the wardrobe carefully, and make markings where the lift mechanism shall be fixed.

### NOTE!

\* It is very important that the wardrobe is fixed to the wall, so that it cannot tilt forward.

\* The installation technician is responsible for that sufficient method and dimensions are used for the installation in the wardrobe. The wall properties, such as porosity, and the type of attachment components will be decisive for the requirements. Be aware of that the Wardrobe lift can have an overall weight of more than 30 kg plus dynamic effects from the motions.

**The installation work must be made by competent persons!**

### 4.4.1

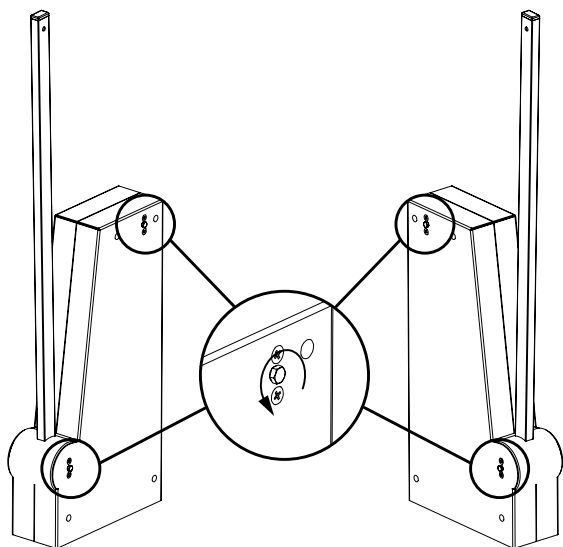

### 4.4.2

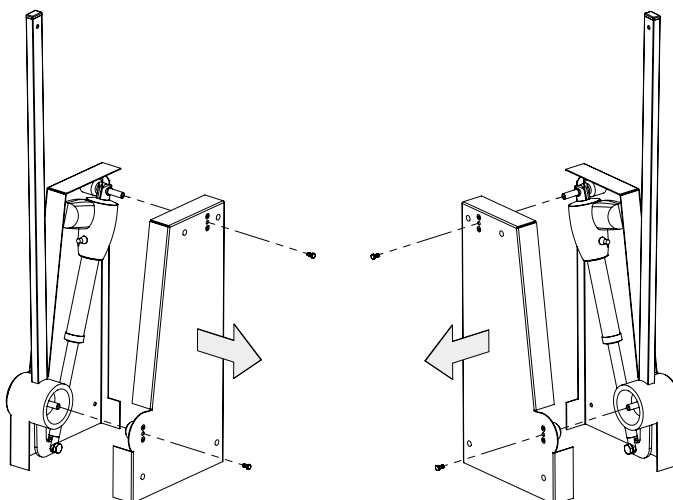



#### 4.4.3

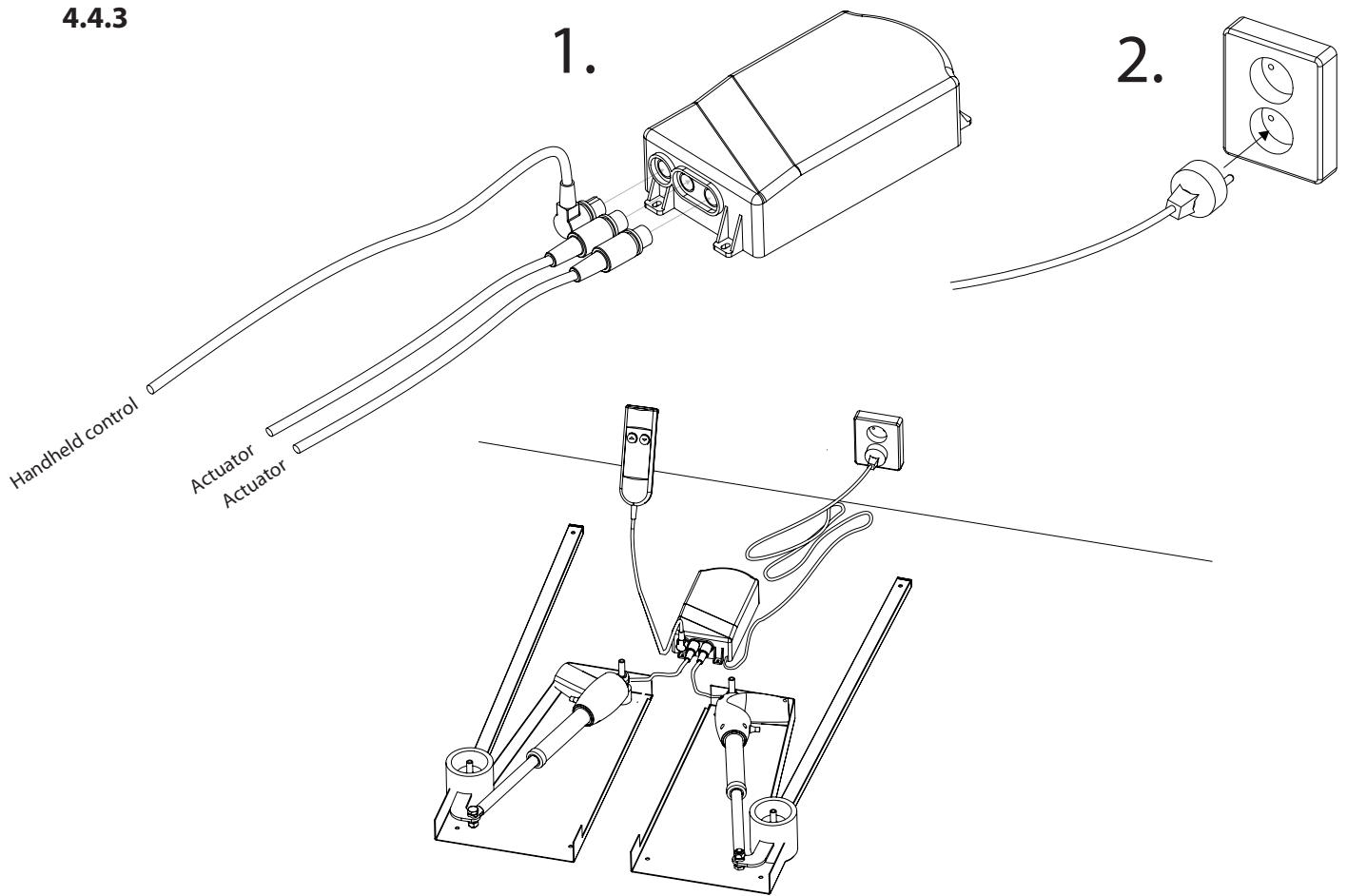

**4.4.4** Operate the lift arms to the shown position acc. to picture below.

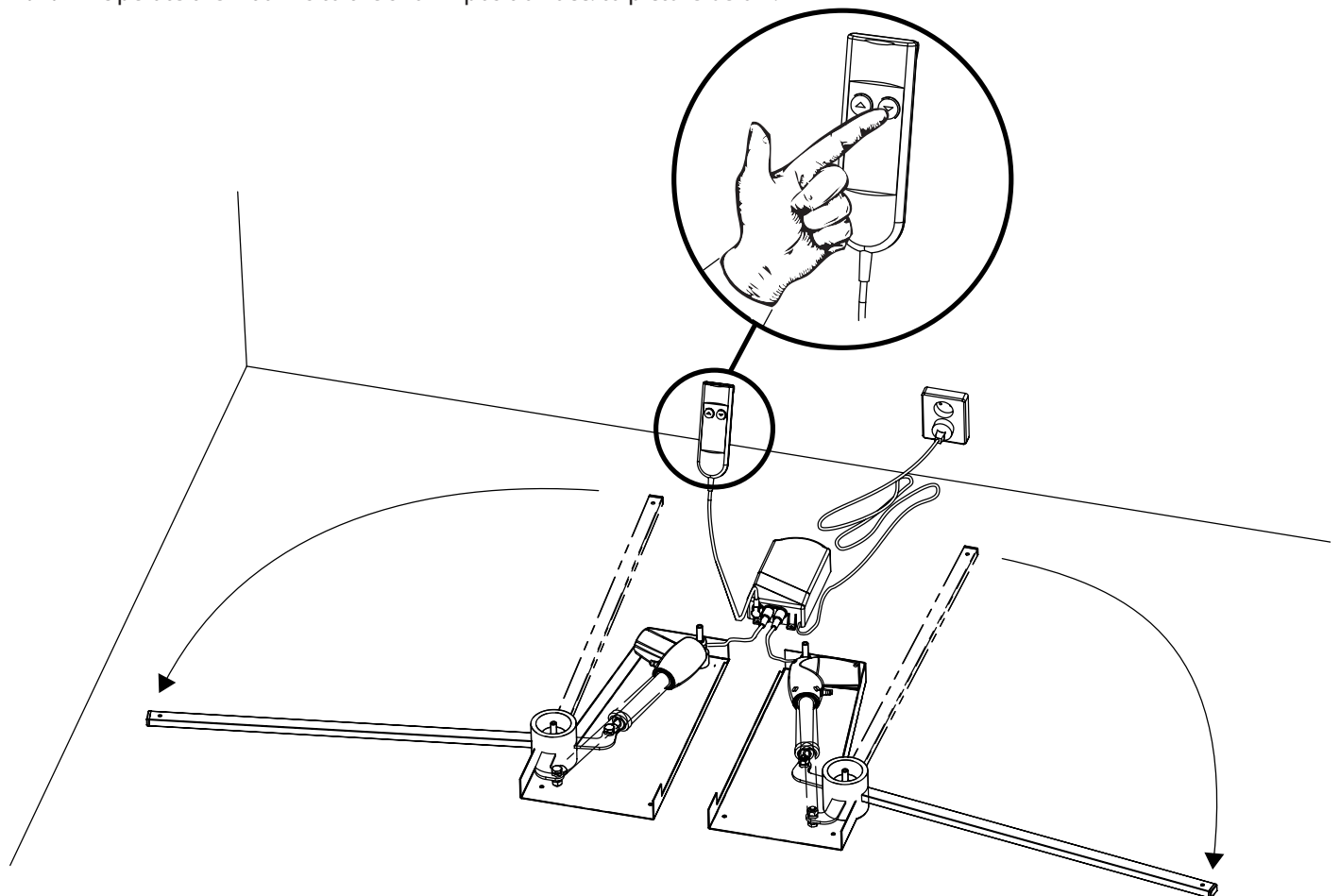

- 4.4.5** Measure and mark the location on the left and right hand inside of the cabinet where the lift mechanisms shall be fixed
- \* The A-measure must not be less than 465 mm.
  - \* For a standard wardrobe with depth 565 mm the B-measure is recommended to be 330 mm. If the wardrobe is deeper than 565 mm the B-measure can be increased.

- 4.4.6** Fix each lift mechanisms with 4 screws to the sidewalls in the cabinet.  
The included screws are suitable for a chipboard or massive wall. Other materials, such as a Masonite wall can require other attachment devices.

- 4.4.7** Check that the lift mechanisms are perfectly vertical by means of a water level.

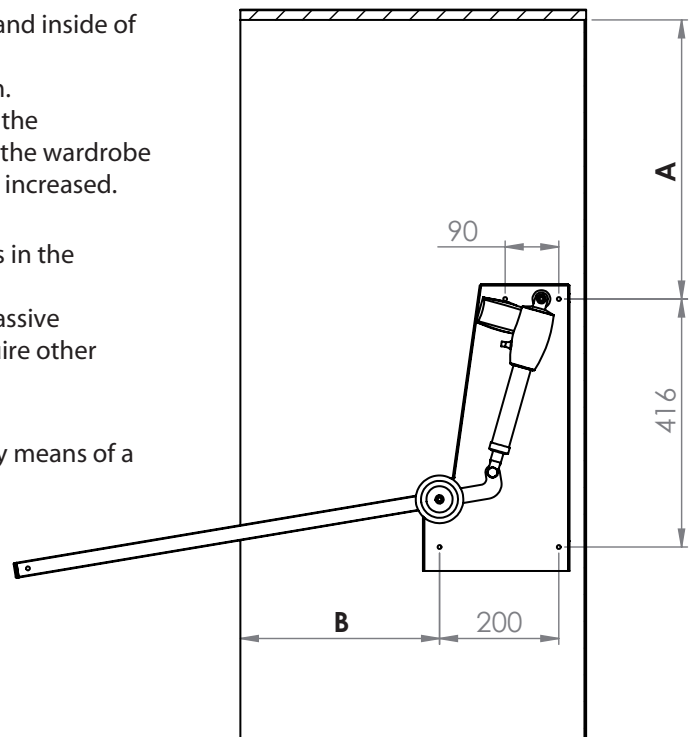

**4.4.8**

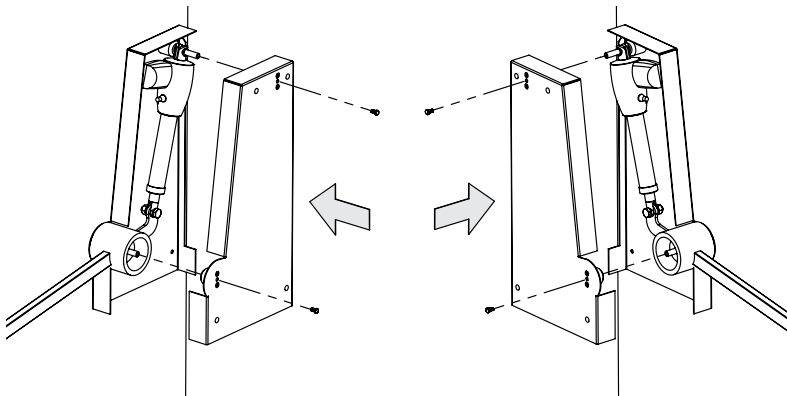

**4.4.9**

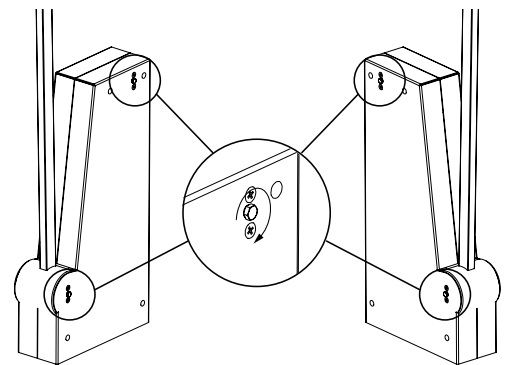

**4.4.10**

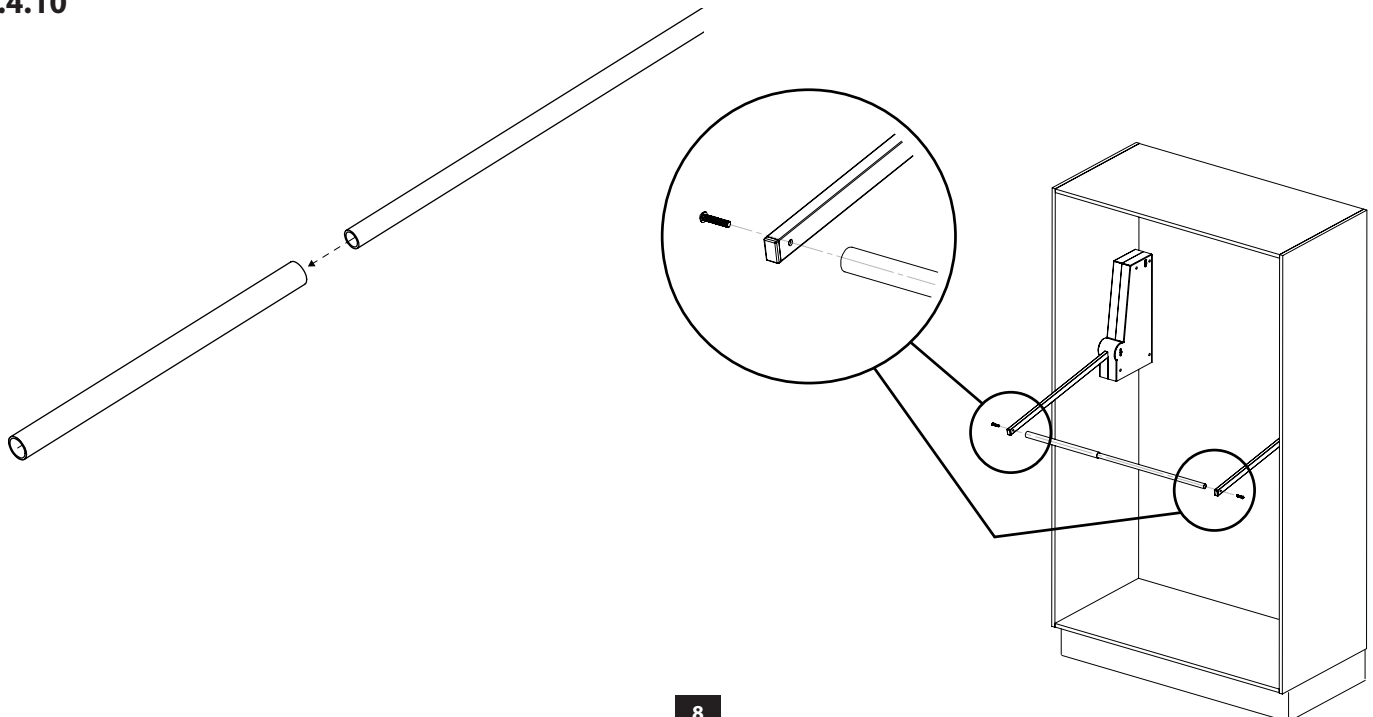



#### 4.4.11

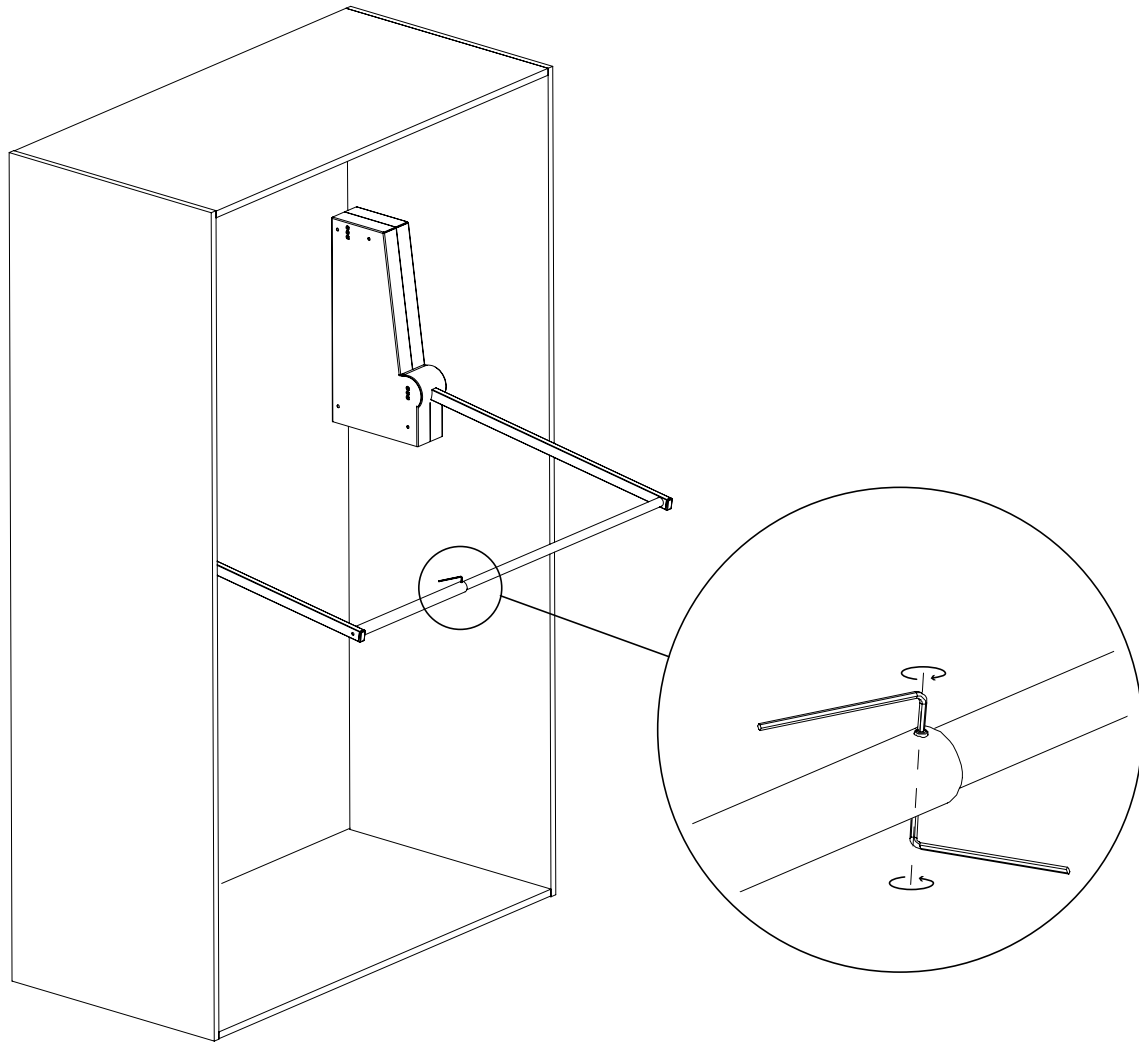

#### 4.5 Location of the cable hand control:

A handheld cable hand control is delivered as standard, and this shall be placed in the wardrobe, or on the inside of the wardrobe door. Thereby it is prevented that the Wardrobe lift is operated before the door has been opened.

**Check the position of the cable carefully, so that it cannot be jammed.**

#### 4.6 Functional test

After installation a complete functional test with full load shall be made:

Run the Wardrobe lift down and up all the way to respectively end position. Check that it moves freely, without hindrance and jarring sounds. Check that no cables are jammed.

## 5.1 Safe use

The Wardrobe lift is provided with safety arrangements in order to prevent and avoid damages and accidents. It is however still very important that the operator is well instructed in how to install and operate the Wardrobe lift.

- Only use the Wardrobe lift for its intended purpose, i.e. storing of clothes.
- The operation and use must be made in such way that there is no risk for damages on persons and property.
- The Wardrobe lift may only be operated by persons who have read and understood these instructions, and are authorized to use it.
- Be aware of that you as an operator are responsible for that nobody is damaged.
- The Wardrobe lift and the work area must be in proper condition. The Wardrobe lift must not be used if any fault has appeared which influences the functions or the operation safety. It shall also not be used if it has been repaired, altered or adjusted without permission of a responsible person.
- Make sure that the Wardrobe lift is installed on firm, flat and absolutely vertical walls with sufficient mounting details, enough for the total weight. Competent persons shall carry out the installation work.
- The operator shall have a clear view of the hazardous parts of the Wardrobe lift, the cabinet and the area around it all the time when operations are taking place.
- Do not touch any part of the lift when operating it. Only press the button for desired motion direction.
- Do not put hands, arms, or any other part of the body or any object in the lifting device when the Wardrobe lift is brought from the parking position. The parking position means when the Wardrobe lift is fully raised and brought to the wall, i.e. at the top level.
- The wardrobe door shall be fully open when the Wardrobe lift is operated.
- Keep in mind that when the Wardrobe lift has left the parking position, the risk increases to get damaged by the lift or the open door.
- Do not lower the Wardrobe lift unless the space below it is free from persons or obstacles.
- Observe the trapping risk between the Wardrobe lift and the wardrobe walls.
- Only stabile and securely loaded items may be handled. Hangers must be suitable for the clothes, and in good condition.
- Never let the Wardrobe lift come in contact with adjacent objects.
- Alterations of the Wardrobe lift that influence the operational safety or the functions are not allowed.
- Decals and markings must not be removed or made illegible.
- Do not overload the Wardrobe lift.
- Use safe and sufficient lifting methods when handling clothes to and from the Wardrobe lift. In particular beware when handling heavy items, and clothes with dangerous content or sharp parts, such as needles.
- The Wardrobe lift shall regularly, once a year, be inspected in order to prevent accidents.
- Applicable Building and Safe use Regulations must be complied with.
- It is forbidden to stay in the wardrobe, to hang on the Wardrobe lift or to use the lift for lifting persons.
- Do not use the Wardrobe lift as a lifting jack, e.g. for lifting things from the floor.
- Do not use the Wardrobe lift in a potentially explosive environment.
- When the operation is in a public location, particularly when children can enter the work area, the operator shall make satisfactory arrangements to prevent persons from entering the hazardous area when the lift is being operated, or it has been lowered from the parking position, e.g. by means of blocking the work area or by means of adding protection devices.
- During inspections, service and repair work there shall be no clothes on the lift.
- Competent persons only must carry out installation, service and repair works.
- Only Granberg original spare parts shall be used when replacing any parts. Our warranty commitment can otherwise be invalidated.

## 5.2 Load distribution and side forces

Note that the max. rated load 20 kg means that the load is distributed over the clothes-rail.

Point loads are not allowed.

### Basic loading requirements:

- \* **The load is distributed over the entire clothes rail.**
- \* **Horizontal forces are not allowed.**

Horizontal forces can appear, for example, when pressing onto the Wardrobe lift or the load.

It is difficult to estimate the size of the actual horizontal force, so utmost care must always be taken.

Further to the incorporated safety arrangements additional can safety actions may be required on or at the Wardrobe lift.

Discuss suitable actions with your Granberg representative or with the health and safety inspection.

**We recommend that a Risk assessment in accordance with the Machinery Directive shall be made for the actual working conditions.**



**Incorrect load distribution!**  
All items placed to the right.

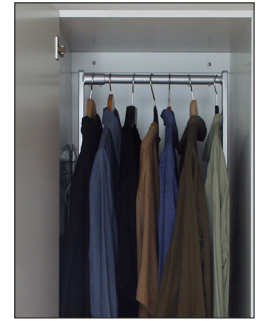

**Correct load distribution!**  
The clothes are uniformly distributed on the rail.

## 5.3 Actions after use

The Wardrobe lift shall after use be left fully raised to the top level, the parking position.

Switch off the main switch or take out the electric plug if unauthorized use can occur. To prevent unauthorized use it can also be possible to place the push button box inside a lockable cabinet.

## 5.4 Alternative control devices

As standard a handheld control with spiral cable is provided, which is handheld during operation. It should be placed at a suitable position, e.g. on the left inside of the wardrobe. See section 4.5 for suitable location.

### NOTE!

If the handheld control is placed outside the wardrobe it is important that the door is opened before the Wardrobe lift is operated.

#### Remote control with handheld control unit



The IR-receiver is placed in the wardrobe and is connected to lift's control device socket.

Before the receiver is permanently fixed, check that it is placed so that the signals from the hand unit reach the receiver when the operator is on a convenient and safe control position.

**See also section 5.1, "Safe use", regarding safe conditions and risks at handling the machine and the load!**

## 5.5 Cleaning

In its use in a house the mechanism can be exposed to dirt. As the Wardrobe lift contains electrical components it is very important that cleaning is made according to this instruction.

### **WARNING!**

**\* The Wardrobe lift must absolutely not be connected to the electric supply when cleaning is carried out.**

**\* The Wardrobe lift must absolutely not be rinsed with water!**

### **Care instructions:**

The Wardrobe lift is cleaned with lukewarm water and a non-scratching detergent containing soap or similar. Use a Wettex swab or similar. After cleaning the surfaces shall be dried to avoid lime deposits.

**Scratching detergents or tools e.g. steel wool may not be used.**

The wardrobe shall be cleaned and maintained in accordance with the manufacturers' instructions.

## 5.6 Maintenance

The Wardrobe lift is maintenance-free. Greasing and other actions are made during the manufacturing for the lifetime of the lift. From safety point of view however some components shall be inspected each year.

\* Inspections, service and repair work shall be made by competent persons.

\* Remove the objects from the Wardrobe lift before maintenance and repair works are made.

1. Run the lift down and up all the way to resp. end position. Check that it runs freely without trapping risks and jarring sounds. Check that it stops and stays in the lower resp. upper positions.
2. Check that the cables are not chafed, squeezed or breaking.
3. Check that the attachments are in proper order.

Accomplished inspections and repair works shall be specified in the service records in section 9.

## 6. Instructions for recycling

When the Wardrobe lift shall be re-used shall it must be cleaned, inspected and go through a full operation test before it is installed on the new site.

We recommend the machine to be sent to Granberg or to the Granberg distributor to get this done.

The machine is manufactured from re-usable materials or from materials that can be recycled.

## 7. Decals

Two decals are included in the instruction manual envelope, and these must be placed in the wardrobe.

The decal that explains that the wardrobe is specially equipped shall be placed close to the handheld control.



The Max. load decal shall be placed at the handheld control.



## 8. Warranty

In accordance with the warranty conditions Orgalime S 2000 the manufacturer will replace or repair all faults which depend on manufacturing or material faults and which appear within twenty-four (24) months from the delivery. For further details about the conditions, see Orgalime S 2000.

Note! Alternative warranty conditions may apply. See the Order Acknowledgement for actual conditions.

The warranty is only valid if inspections and maintenance is carried out in accordance with the instructions. This warranty does not cover the cost of normal maintenance, settings or scheduled adjustments as specified in the instructions. Also the labour costs for such actions are not covered by the warranty.

Damages caused by misuse or incorrect operation of the equipment means that the warranty would expire.

Before any warranty work is commenced by a customer Granberg must be contacted for analysis and approval. We do not accept to carry any warranty costs if the repair work has started without an agreement by us.

Do not return any parts that have been worn out during normal operation or accidentally damaged. Only return worn or damaged parts if it is considered that the fault is covered by our warranty conditions. In such cases, return the parts without delay, otherwise the right to replacement may be lost.

When returning parts always quote the details shown on the manufacturer's plate, i.e.

Type, manufacturing number, year

and describe the operating conditions for the machine.

**Remember to quote name, address and telephone number for the appropriate contact person.**

## 9. Service and Maintenance Records

Service & maintenance	Service & maintenance	Service & maintenance
Date: _____	Date: _____	Date: _____
Sign. _____	Sign. _____	Sign. _____
Remarks: _____	Remarks: _____	Remarks: _____
_____	_____	_____
_____	_____	_____
_____	_____	_____

## 10. Fault finding

The Wardrobe lift is designed and tested to achieve optimum operation reliability and long life, provided that the operation, maintenance and inspections are carried out in accordance with the prescribed instructions. If in spite of this a fault appears you can get guidance about what to do according to the faultfinding list below.

Remove the clothes from the rail before fault finding and repair work is carried out.  
Fault finding, service and repair work shall be made by competent persons only.

If any problem remains after you have taken actions in accordance with the list below you must contact a competent technician or your supplier.

Symptom	Action
The machine does not move when a control signal is given.	Check that the fuse for the mains feed is not damaged.
	Check that the mains plug is connected.
	If the Wardrobe lift still does not move contact an authorized technician and/or your supplier.
	This shall as first action, after above check points, check that all cables are connected and undamaged, and that the green light on the control box is lighting.
	If it is not lighting the control box is probably defect. Order a new unit from Granberg.

**When repair work has been carried out on the Wardrobe lift a complete functional test with full load shall be made, before it is taken into use. (See section 4.6).**

## 11. Spare parts list

If any component does not work or has broken, contact your supplier. Only Granberg original spare parts must be used when replacing any parts. Our warranty commitment may otherwise be invalidated.

### Return of spare parts:

Contact Granberg prior to any return of parts.

Do not return any parts that have been worn out during normal operation or accidentally damaged. Only return worn or damaged parts if it is considered that the fault is covered by our warranty conditions. In such cases, return the parts without delay, otherwise the right to replacement may be lost.

When ordering spare parts always quote the manufacturing number and type.

- A - Lift mechanism, left
- B - Lift mechanism, right
- C - Control unit
- D - Handheld control unit with spiral cable
- E - Rail tube
- F - Hanger for handheld control
- G - 12 off screw 4x16 mm

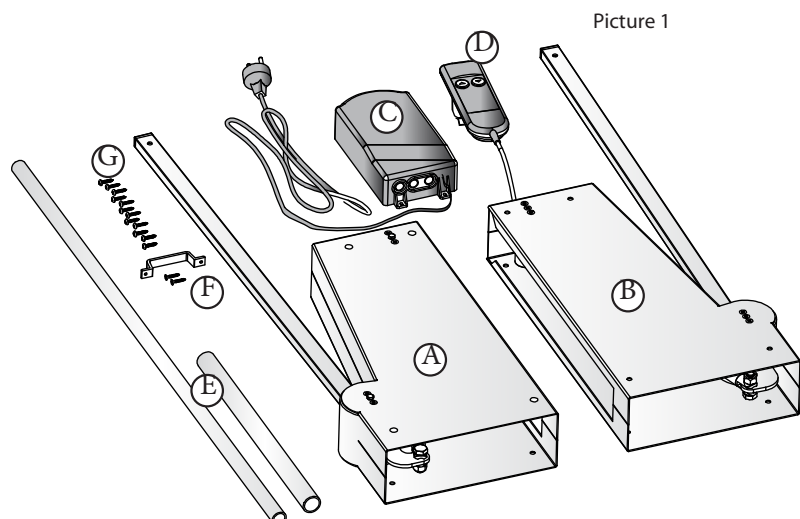



## 12. Electric circuit diagram

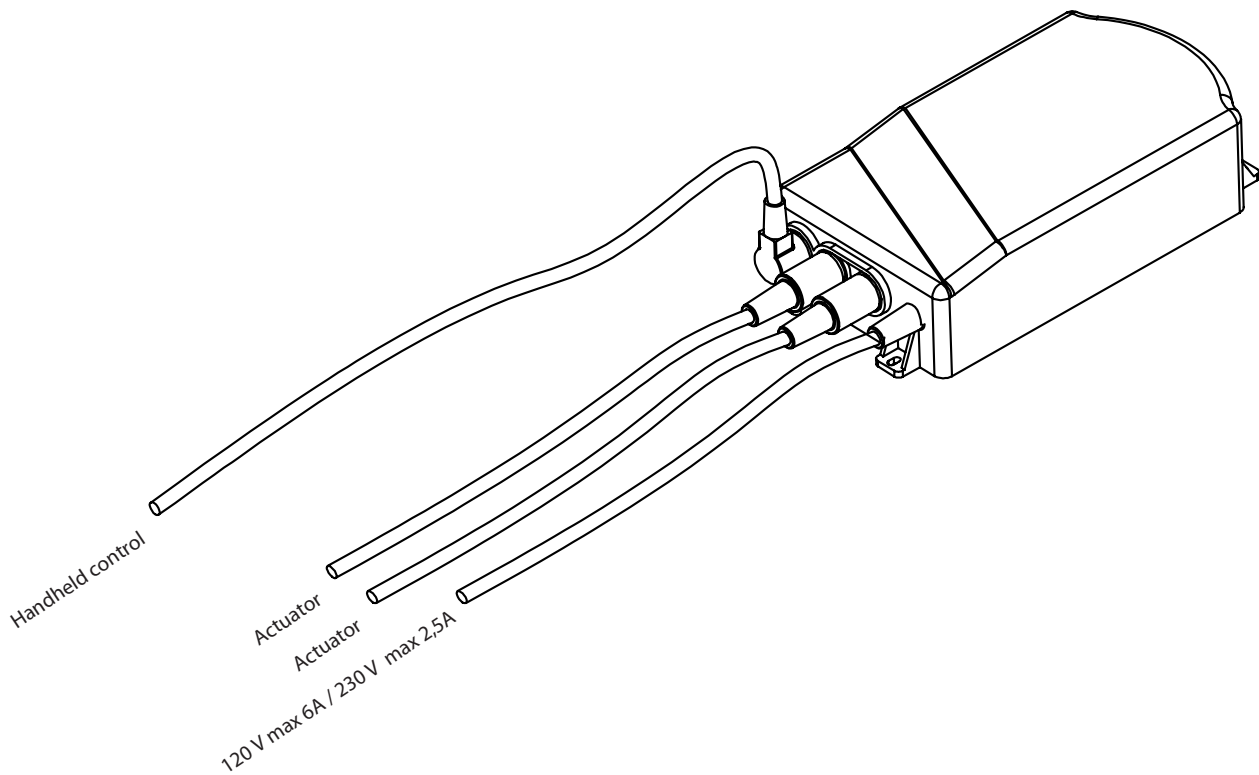

## 18. CE-Declaration of conformity

(According Machinery Directive 2006/42/EG, Annexe 2A)

Manufacturer: Granberg Interior AB  
Box 6112,  
SE-600 06 NORRKÖPING, Sweden

Tel. +46-11-19 77 50  
Fax +46-11-12 76 76



declares under sole responsibility that the product:

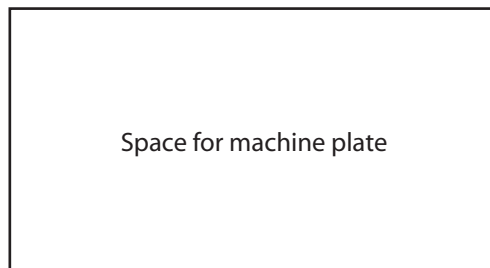

to which this declaration relates, is in manufactured in conformity with the following harmonised documents, following the provisions of Machinery Directive 2006/42/EG, the Low Voltage Directive 2006/95/EG and the EMC Directive 2004/108/EG.

It also conforms to the following harmonised standards:

EN 60204-1 Safety of Machinery - Electrical Equipment of Machines -General Requirements

Norrköping, 2012-12-10  
Granberg Interior AB

Tobias Granberg  
Managing Director



Box 6112 SE-600 06, Norrköping Sweden  
Tel: +46 (0)11-19 77 50 Fax: +46 (0)11-12 76 76  
E-mail: [info@granberg.se](mailto:info@granberg.se) - Internet: [www.granberg.se](http://www.granberg.se)